

TOMEI The Engine Specialist Camshaft Spec Card

PART NAME PROCAM ENGINE VR38DETT

PART NUMBER SET TA301A-NS01C IN TA301C-NS01C EX TA301E-NS01C

GRIND	IN	282° /11.30mm	SOLID
	EX	282° /11.30mm	SOLID

LIFT	IN	@CAM 11.30mm	@VALVE 11.00mm
	EX	@CAM 11.30mm	@VALVE 10.97mm

LOBE CENTER(°)	IN	124.0
	EX	115.0

BACE	IN	Φ35.4
	EX	Φ35.4

VALVE CLEARANCE WHEN COLD	IN	0.30mm
	EX	0.33mm

ROCKER ARM RATIO*	-
-------------------	---

* ALL LIFTS ARE BASED ON ZERO LASH AND THORETICAL ROCKER ARM RATIOS

CAM TIMING		OPENS(°)		CLOSES(°)		Actual Duration @ Opening (°)
Actual Duration	IN	BTDC	16.0	ABDC	86.0	
Valve Lift	EX	BBDC	75.0	ATDC	27.0	282.0

Values shown are, from start to the end of actual duration. (Excluding the ramp values)

CAM TIMING		OPENS(°)		CLOSES(°)		TOTAL DURATION(°)
at 1mm Valve Lift	IN	TDC	0.0	ABDC	70.0	
	EX	BBDC	59.0	ATDC	11.0	250.0

Values are of actual duration from start to end of 1mm value points. (Excluding the ramp values)

CAM TIMING		OPENS(°)		CLOSES(°)		TOTAL DURATION(°)
at 0.05" Valve Lift	IN	ATDC	2.0	ABDC	68.0	
	EX	BBDC	57.0	ATDC	9.0	246.0

Values are of actual duration from start to end of 0.05" value points. (Excluding the ramp values)

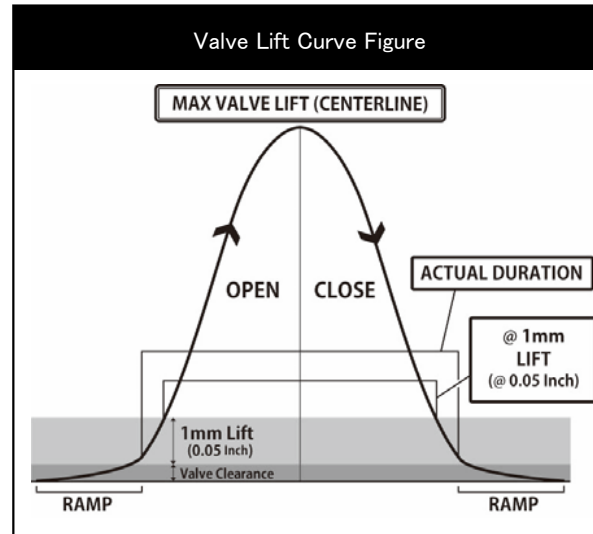

REQUIRED VALVE SPRING SPEC		
NOMAL HEIGHT	IN	45.1mm EX 45.1mm
SET LENGTH		36.6mm 33.7mm
LIFT LENGTH		25.6mm 22.5mm
COMPRESSED HEIGHT		21.7mm 21.7mm
SET LOAD		22.0kgf±6% 32.0kgf±6%
LIFT LOAD		60.0kgf±6% 70.0kgf±6%
PART NUMBER	TA304A-NS01A	

REQUIRED PARTS	
PRODUCT NAME	PART NUMBER

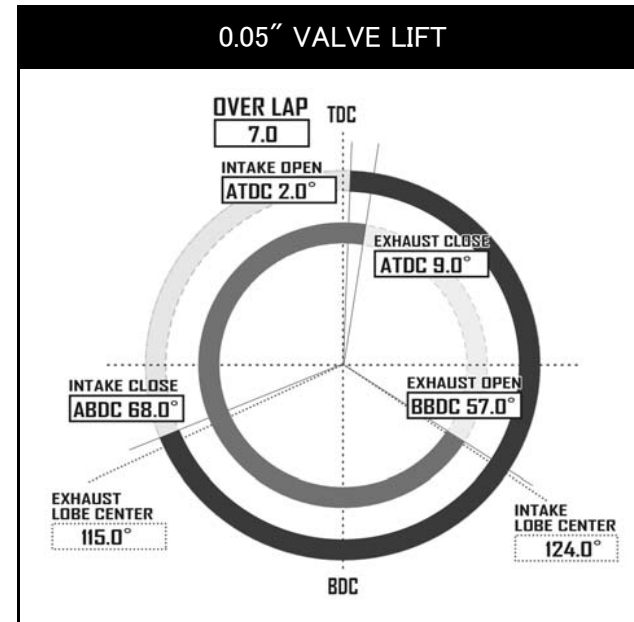
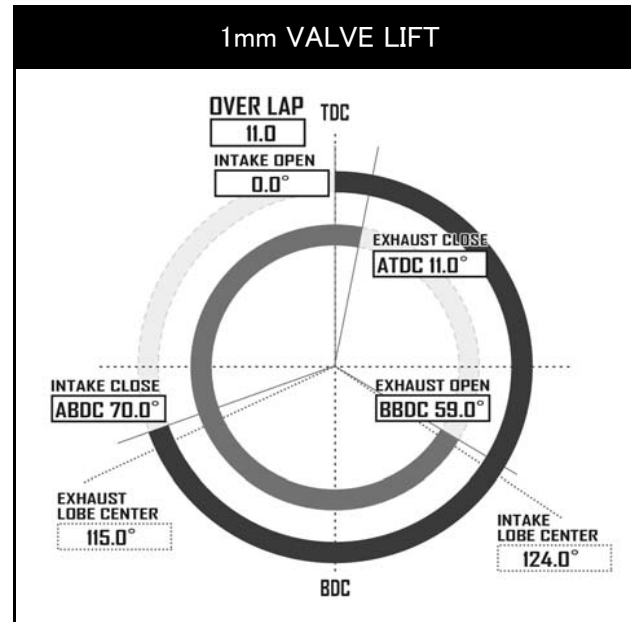
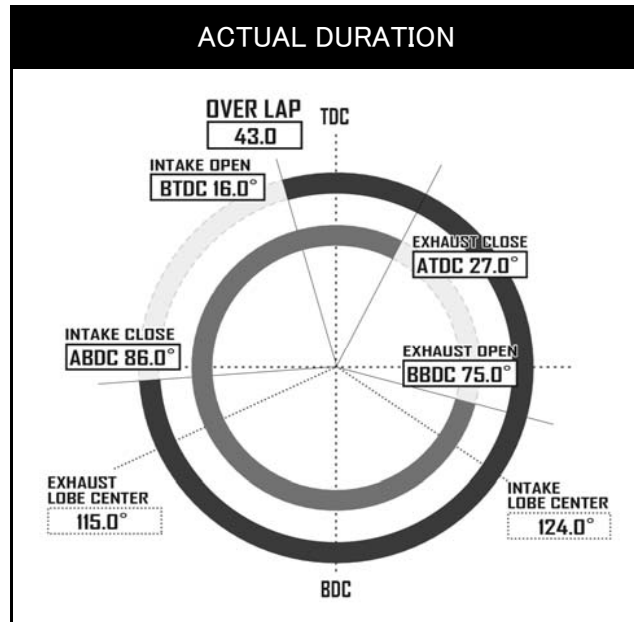

Dowel pin position when first cam lobe is pointing upwards.

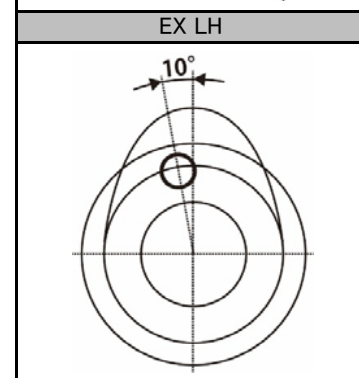
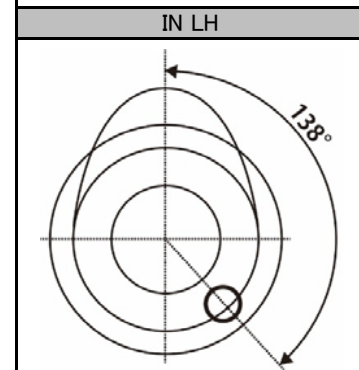
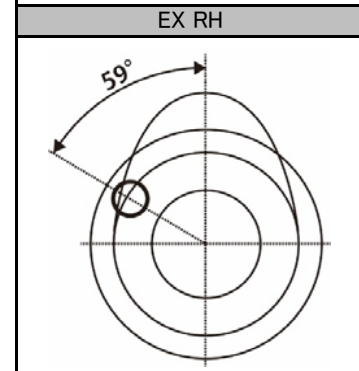
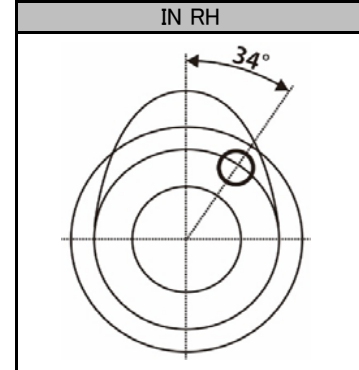

TOMEI Camshaft Spec Card

The Engine Specialist

品名 PROCAM 適合 VR38DETT

品番 SET TA301A-NS01C IN TA301C-NS01C EX TA301E-NS01C

スペック	IN	282° / 11.30mm	SOLID
	EX	282° / 11.30mm	SOLID

リフト	IN	@CAM 11.30mm	@VALVE 11.00mm
	EX	@CAM 11.30mm	@VALVE 10.97mm

初期設定 中心角(°)	IN	124.0
	EX	115.0

ベース円	IN	Φ35.4
	EX	Φ35.4

冷間時 バルブクリアランス	IN	0.30mm
	EX	0.33mm

ロッカーアームレシオ*	-
-------------	---

* すべてのリフト値はラッシュアジャスターが動作していない時、およびロッカーアームレシオから計算した理論値です。

カムタイミング		OPENS(°)		CLOSES(°)		Actual Duration @ Opening(°)
有効作用角 バルブリフト	IN	BTDC	16.0	ABDC	86.0	282.0
	EX	BBDC	75.0	ATDC	27.0	282.0

ランプ部を除いた有効作用角の始点と終点の数値

カムタイミング		OPENS(°)		CLOSES(°)		TOTAL DURATION(°)
1mm バルブリフト	IN	TDC	0.0	ABDC	70.0	250.0
	EX	BBDC	59.0	ATDC	11.0	250.0

ランプ部を含めたバルブの開き始めと閉じ終わりから1mmの点での数値

カムタイミング		OPENS(°)		CLOSES(°)		TOTAL DURATION(°)
0.05" バルブリフト	IN	ATDC	2.0	ABDC	68.0	246.0
	EX	BBDC	57.0	ATDC	9.0	246.0

ランプ部を含めたバルブの開き始めと閉じ終わりから0.05インチの点での数値

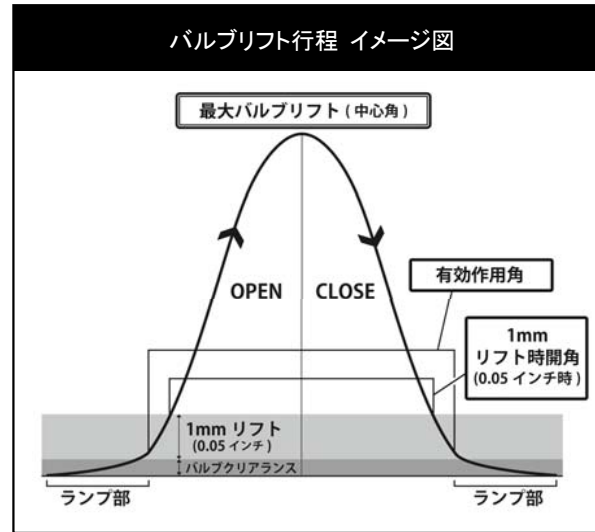

推奨バルブスプリング				
自由長	IN	45.1mm	EX	45.1mm
セット長		36.6mm		33.7mm
リフト長		25.6mm		22.5mm
密着長		21.7mm		21.7mm
セット荷重		22.0kgf±6%		32.0kgf±6%
リフト荷重		60.0kgf±6%		70.0kgf±6%
品番	TA304A-NS01A			

必要部品	
製品名	品番

